

ROAD TEMPERATURE SENSOR 3304

The Road Temperature Sensor has been designed for use with Automatic Weather Station AWS 2700 and Aanderaa Dataloggers. The sensor is intended for embedding in the tarmac of the road surface.

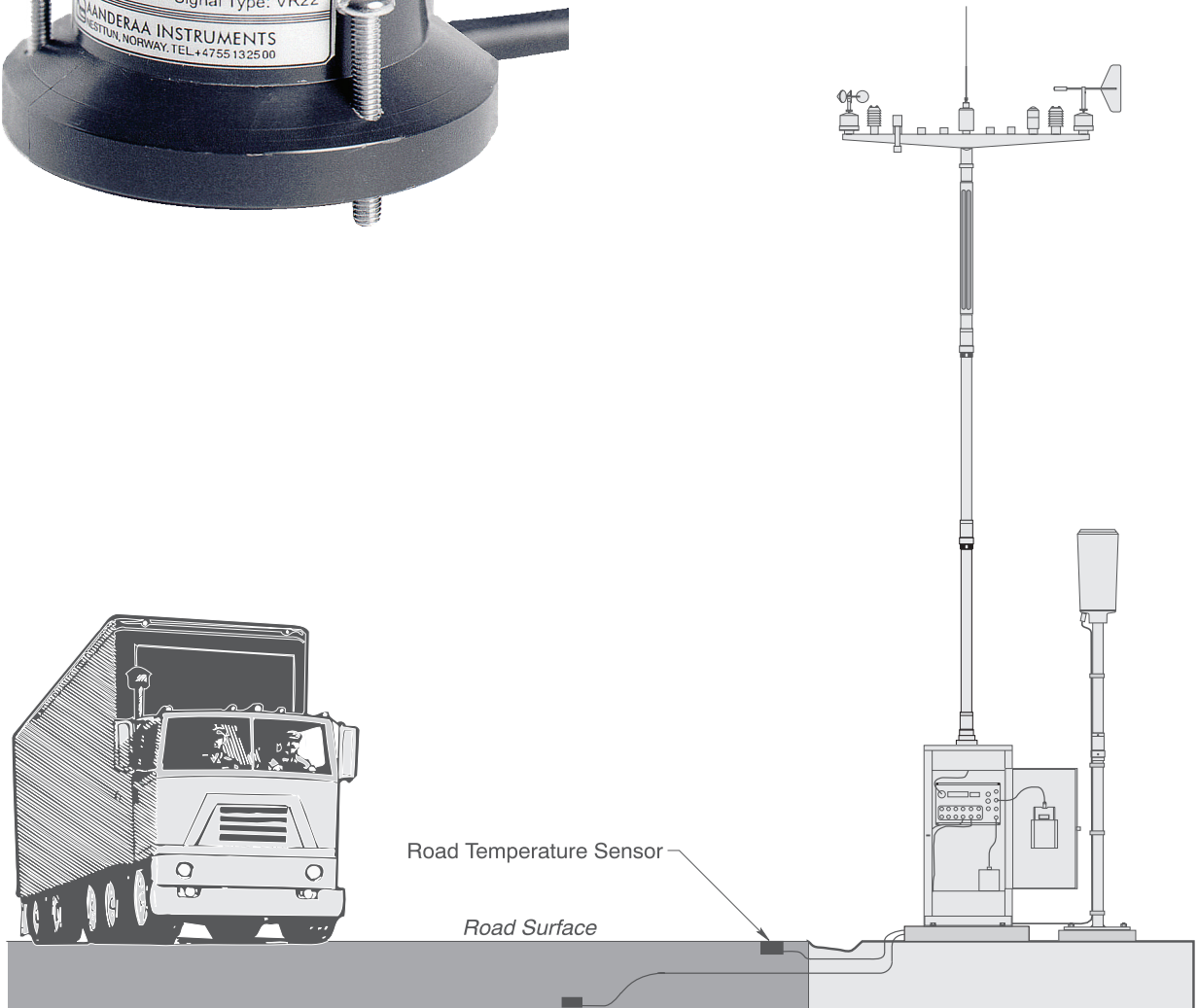

The temperature of the road surface is of great importance to the road authorities and road maintenance people, especially during the winter when snow and frost make it risky to travel along our highways. Having access to the road temperature at all times, those responsible can decide what action to take to keep the roads free from ice and snow.

The Road Temperature Sensor 3304 is designed to be embedded in the road tarmac with a fixed durable 15 meter cable and extension cable 2842 that connects the sensor to the Datalogger 3660 in the Road Weather Station nearby.

The sensing element is a platinum resistor, Pt 2000 with positive temperature coefficient. The Pt element, together with 2 resistors, forms a Wheatstone half-bridge which is molded into a mixture of polyurethane and cement.

As the sensor is flush with the road surface it must wear at the same rate as the road tarmac. A vertical polystyrene rod is molded into the sensor for wear indication. When the rod appears on the surface of the sensor, after approximately 12mm wear, the sensor must be replaced.

Specifications

ROAD TEMPERATURE SENSOR 3304

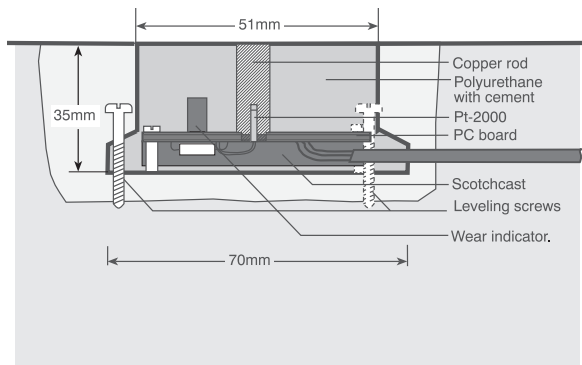
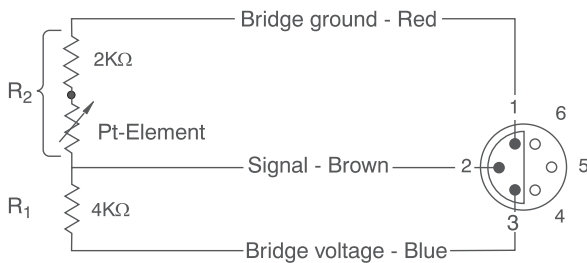

Illustration shows the sensor embedded in the road

CIRCUIT DIAGRAM

Plug, pin = ●; bushing = ○



CALIBRATION

Temperature (°C)	Raw data N

To convert raw data to engineering units use the formula:

$$\text{Temperature (°C)} = A + BN + CN^2 + DN^3$$

- Sensing element:** Platinum Pt 2000
- Range:** -43 to +48°C
- Resolution:** 0.1°C
- Accuracy:** ±0.2°C
- Output:** VR22 (analog)
- Time Constant (63%):** 30 seconds
- Current Consumption:** 70µA during measurement
- Electrical Connection:** 15m fixed cable with 6-pin plug (Other lengths on request)
- Accessories (optional):** Connecting Cable 2842
- Wear Indicator:** Replace sensor when wear indicator is visible (Approx. 12mm wear). See illustration
- Material:** Foss-Than 646 / Cement MP-30
- Weight:** 1100 grams with 15 meter cable

Serial No:

Calculated coefficients:

A		C	
B		D	0

Date:

Sign:



Visit our Web site for the latest version of this document and more information

www.aadi.no

Aanderaa is a trademark of Xylem Inc. or one of its subsidiaries.
© 2012 Xylem, Inc. D247 January 2013

Aanderaa Data Instruments AS
Sanddalsringen 5b, P.O. Box 103 Midtun,
5828 Bergen, Norway
Tel +47 55 60 48 00
Fax +47 55 60 48 01