



ZPulse® Doppler Current Sensor 4420/4520, 4420R/4520R 4830/4930, 4830R/4930R

A rugged, true vector-averaging sensor for measuring current speed and direction in the sea.

Features ZPulse Doppler Current Sensor:

- Unique ZPulse multi-frequency acoustic technology improves data quality, sampling speed and reduces power consumption
- Smart sensor for easy integration on the SeaGuard platform
- Built in solid state three axis tilt compensated compass
- Direct readout of engineering data
- Fast sampling rate
- Low power consumption
- Insensitive to fouling
- Low maintenance needs
- 4420/4520/4830/4930 model: AiCaP and RS-232 output
- 4420R/4520R/4830R/4830R model; RS-422 output
- 4830/4930/4830R/4930R including temperature

The ZPulse Doppler Current Sensor (DCS) is a single-point current sensor primarily intended to be used with the Aanderaa SeaGuard platform to form a Recording Current Meter (RCM). It is designed for commercial as well as research use. There are 8 versions; 4420/4420R, 4830/4830R has a depth rating of 300 meters, while the 4520/4520R/ 4930/4930R has a depth rating of 6000 meters. 4830/4830R/ 4930/4930R have a temperature sensor included.

4420/4520/4830/4930 has both AiCaP and RS-232 output. The SeaGuard platform and the smart sensor are interfaced by means of a reliable CANbus interface (AiCaP), using XML for plug and play capabilities. 4420R/4520R/ 4830R/4930R has only RS-422 output for use as stand-alone sensor with long cables. The sensor version must be specified when ordered as the versions are not interchangeable. The R-version can not be used in SeaGuard applications.

The DCS sensors are based on the backscatter acoustic Doppler principle. The DCS has two orthogonal transducer axes with two transducers on each axis. This enables the DCS to measure in both directions on each axis which is a great advantage. This makes it insensitive to disturbance from vortex speeds around the sensor itself and the mooring line when the forward ping feature is enabled. One transducer on each axis transmits short ultrasonic pulses simultaneously. The same transducers receive backscattered signals from particles in the water. This gives an orthogonal x and y speed component which is tilt compensated to find the correct horizontal speed components.

The North and East speed components are calculated based on the x and y speed components and the heading from the built-in solid state electronic compass. The sensor takes several of these two-component measurements and finally calculates the averaged north and east speed components and the vector averaged absolute speed and direction.

Another great advantage is the new ZPulse technology which improves the statistical precision. Complex acoustic pulses comprising several distinct frequencies are combined into a single acoustic pulse. The ZPulse based DCS separates the received signal into different frequency bands, one for each frequency in the transmitted signal. Further it analyses the frequency shift using a high speed Digital Signal Processor using an ARMA based parametric model processing algorithm to find the Doppler shift frequencies. This multi-frequency technique reduces the required number of pings needed in order to achieve an acceptable statistical error. The achieved measurement precision is proportional to the inverse of the square root of the number of ping measurements in a measurement interval. The ZPulse DCS uses two frequencies and this gives a reduction by a factor square root of two compared to a single frequency sensor. A single frequency sensor needs twice the number of ping to achieve the same precision as the Zpulse DCS.

The solid state sensor is well suited for monitoring low current speeds due to no moving parts. Because the sensor starts measuring in an area 0.4 to 1.0 meter from the instrument, the effect of marine fouling and local turbulence is minimized.

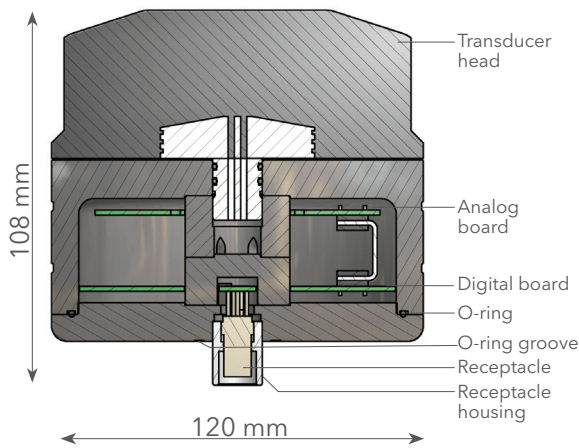

PIN CONFIGURATION

Receptacle, exterior view; pin = ● bushing = ○

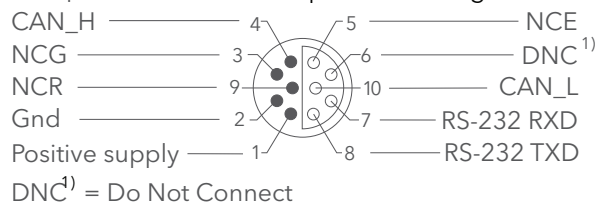

PIN CONFIGURATION 4420R/4520R/4830R/4930R

Receptacle, exterior view; pin = ● bushing = ○

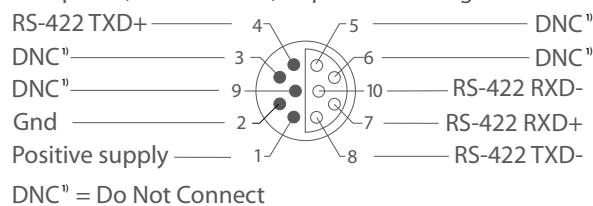

Specifications subject to change without prior notice.

Current Speed: (Vector averaged)
Range: 0-300cm/s
Resolution: 0.1mm/s
Mean Accuracy: ±0.15cm/s
Relative: ± 1% of reading
Statistic precision (std): 0.3cm/s (ZPulse mode), 0.45cm/s¹

Current Direction:
Range: 0-360° magnetic
Resolution: 0.01°
Accuracy: ±5° for 0-15° tilt
 ±7.5° for 15-35° tilt

Temperature (only 4830/4830R/4930/4930R):
Range: -5°C to +40°C
Resolution: 0.01°C
Accuracy: 0.1°C
 Settling Time(63%): 30s

Tilt Circuitry:
Range: 0-35°
Resolution: 0.01°
Accuracy: ±1.5°

Compass Circuitry:
Resolution: 0.01°
Accuracy: ±3°

Acoustics:
Frequency: 1.9 to 2.0MHz
Power: 25 Watts in 1ms pulses
Beam angle (main lobe): 2°

Interfaces:
 4420/4520/4830/4930: AiCaP protocol, RS-232
 4420R/4520R/4830R/4930R: RS-422

RS-232/RS-422 Output: 9600 baud, 8 data bit, No parity, 1 stop bit, Xon/Xoff

Maximum cable length:
 RS-232: 15m
 RS-422: 1500m

Installation distance:
 From surface: 0.75m
 From bottom: 0.5m

Supply Voltage: 6-14 Vdc
Operating Temperature: -5 to +50°C

Depth Capability:
 4420/4830: 300m
 4520IW/4930IW: 3000m
 4520DW/4930IW: 6000m

Electrical Connection: 10-pin plug

Material and Finish:
 4420/4420R: Durotong, POM
 4830/4830R: Durotong, POM, epoxy coated titanium
 4520/4930/4520R/4930R: Durotong, epoxy coated titanium

¹⁾Standard deviation based on 300 pings



Visit our Web site for the latest version of this document and more information
www.aanderaa.com

Aanderaa is a trademark of Xylem Inc. or one of its subsidiaries.
 © 2018 Xylem, Inc. D367 July 2018

Aanderaa Data Instruments AS
 Sanddalsringen 5b, P.O. Box 103 Midtun,
 5843 Bergen, Norway
 Tel +47 55 60 48 00
 Fax +47 55 60 48 01